

Assembly Instruction for Universal Adapters

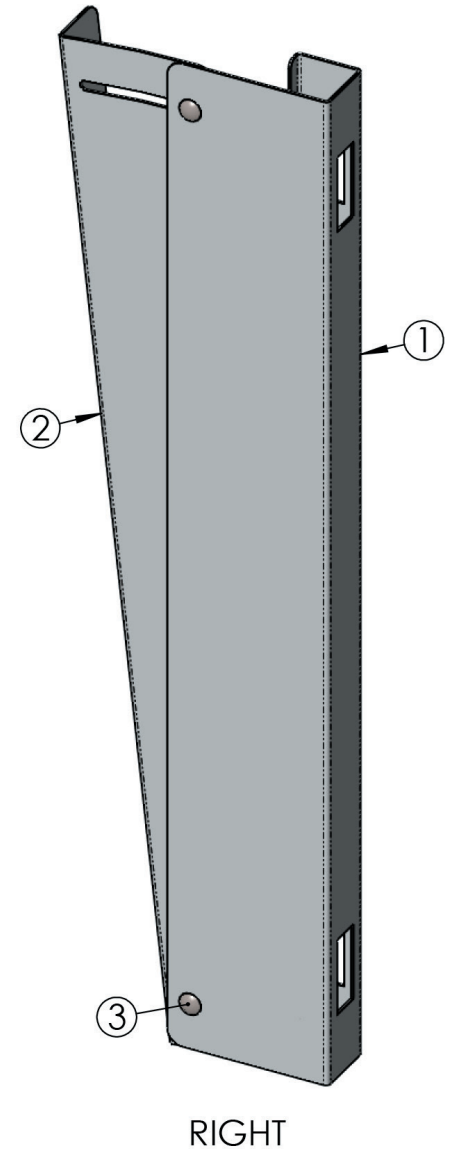

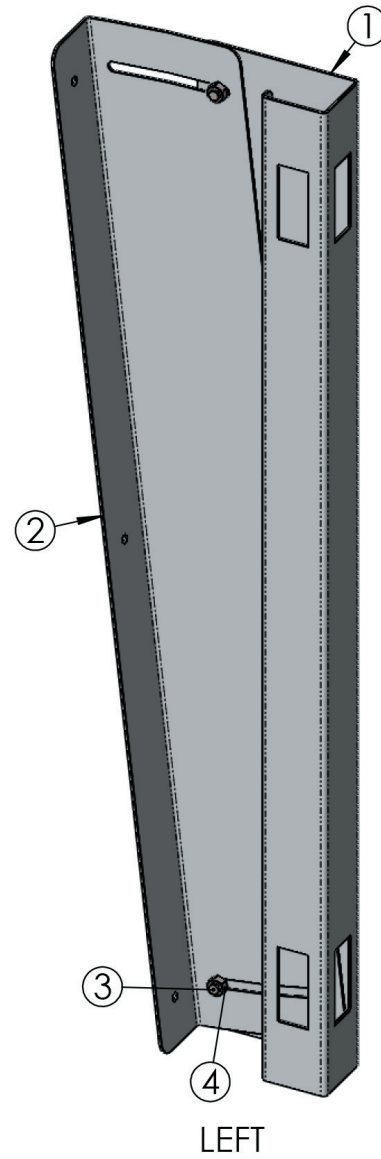

DETAIL A
SCALE 1 : 2

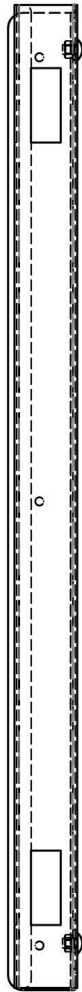
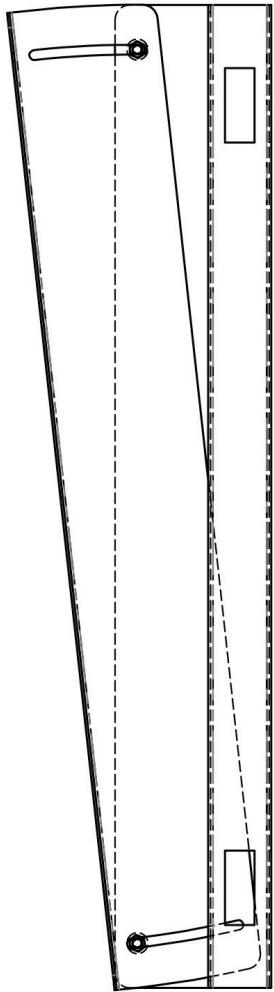
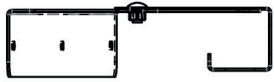
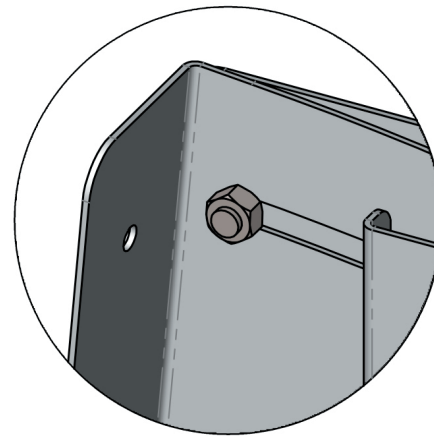
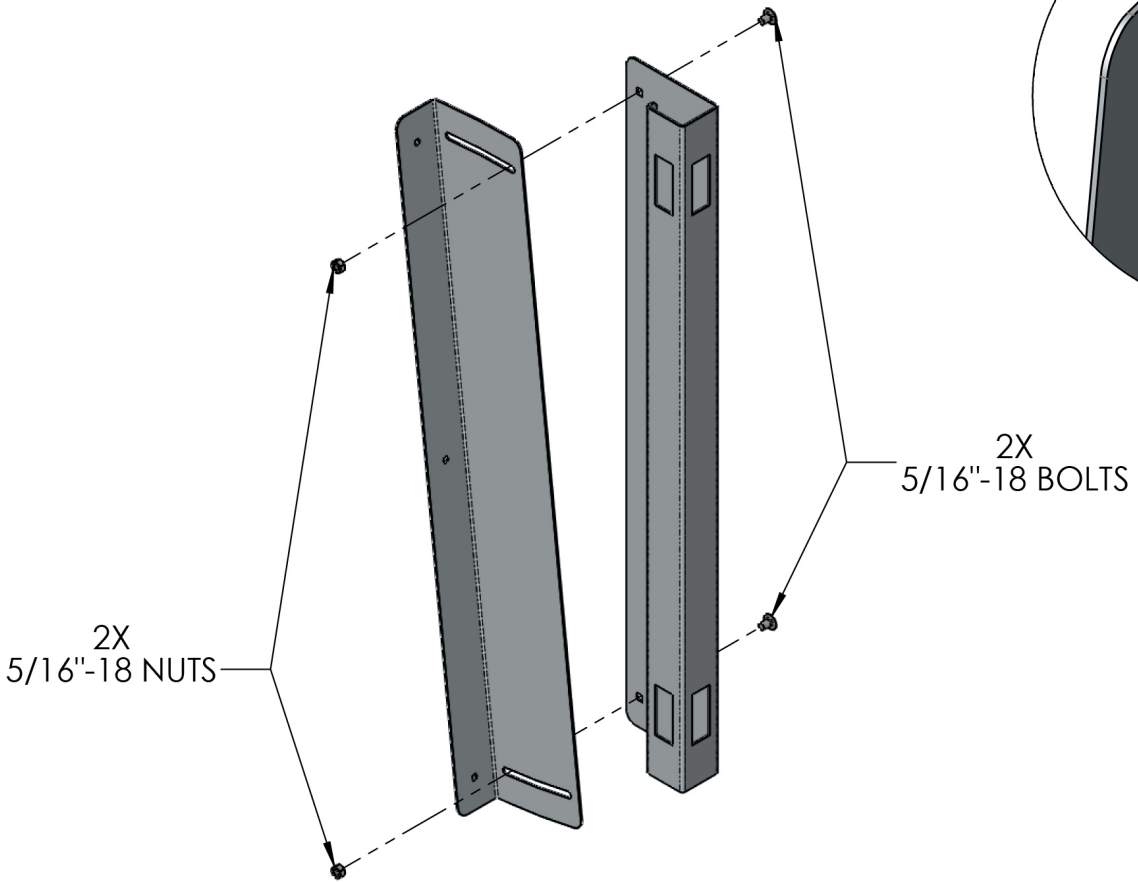
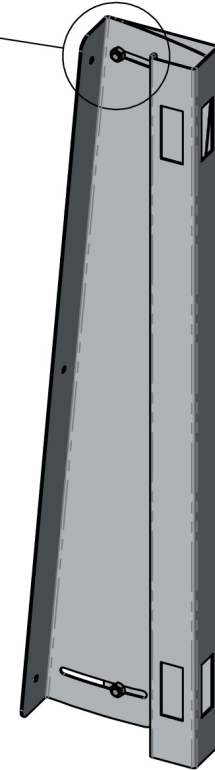

LOOSELY ATTACHE PIECES
TOGETHER USING PROVIDED BOLTS

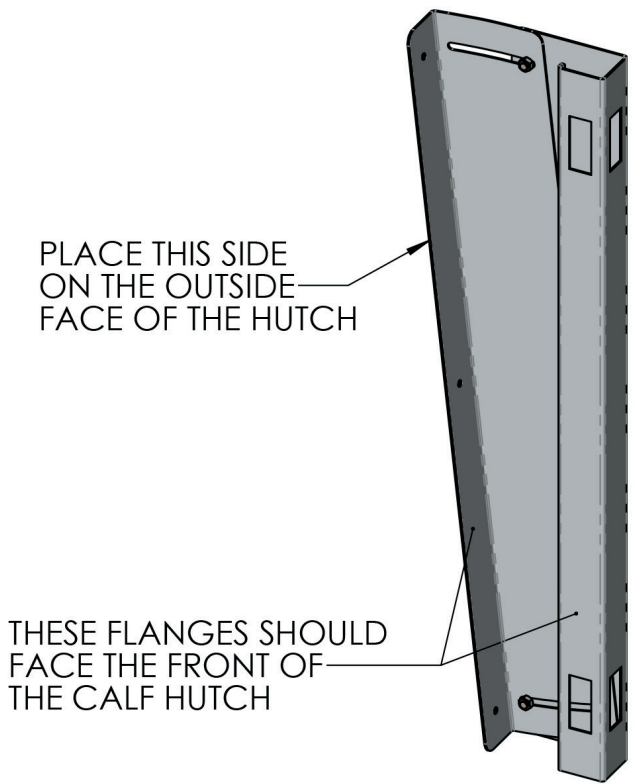

FRONT OF HUTCH

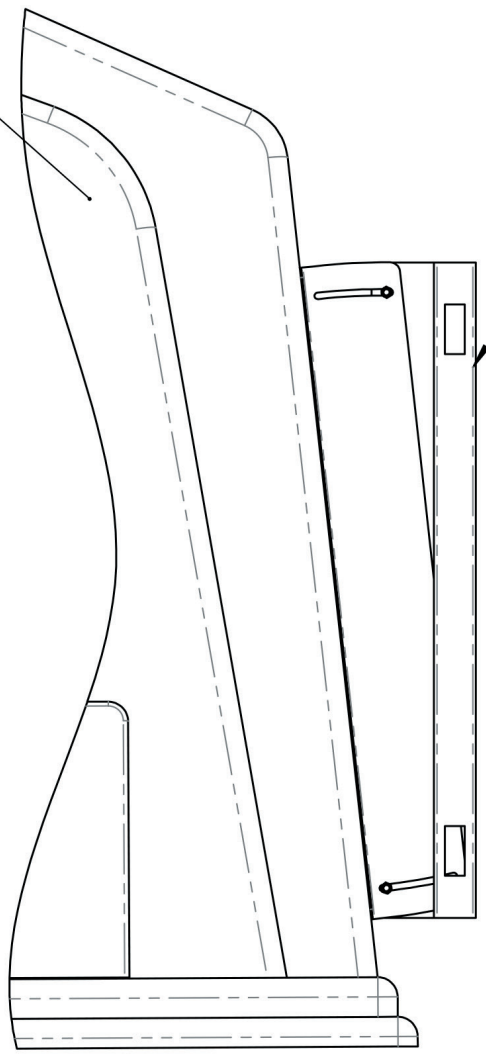

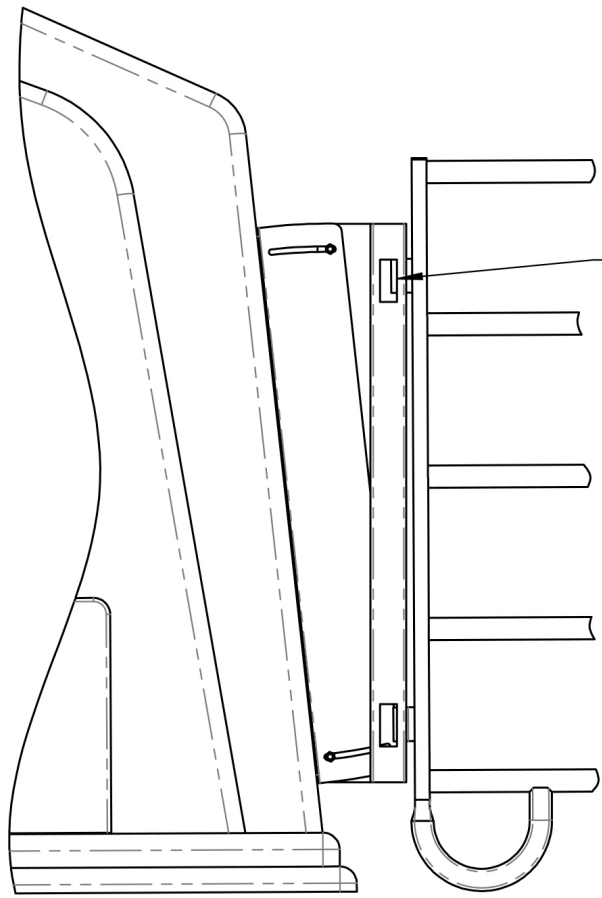

LINE SLOTS UP WITH
PANEL HINGES TO
DETERMINE ADAPTER
PLACEMENT HEIGHT

MARK LOCATIONS
AND DRILL 1/4"
HOLES INTO HUTCH

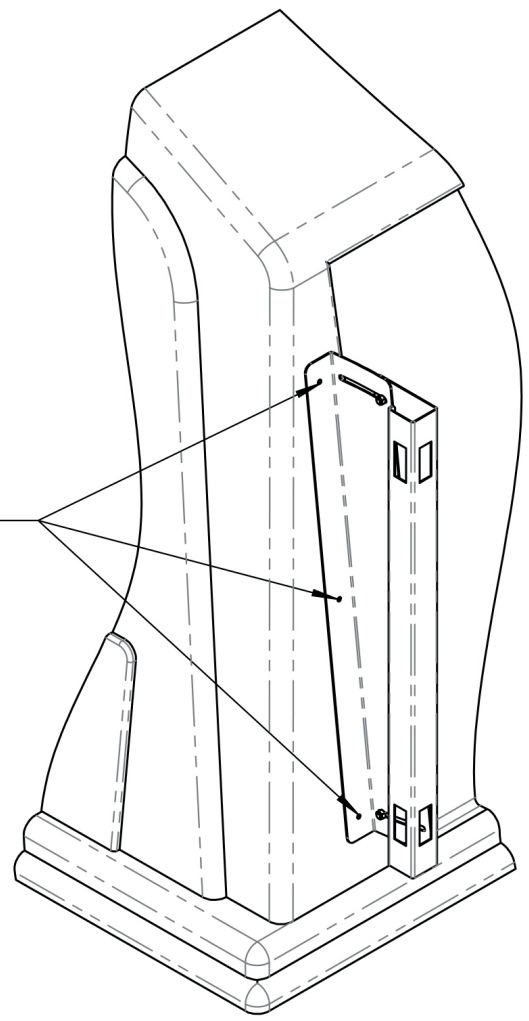

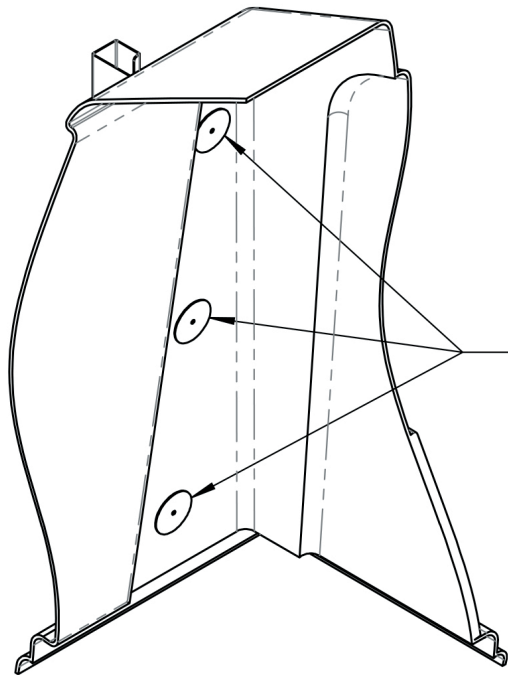

PLACE WASHERS ON BOLTS
INSIDE OF THE HUTCH AND
PUSH BOLTS THROUGH HUTCH

PUT ADAPTER ONTO
BOLTS AND TIGHTEN
DOWN WITH NUTS

